



CSIR - NATIONAL GEOPHYSICAL RESEARCH INSTITUTE
(Council of Scientific & Industrial Research)
Uppal Road, Hyderabad – 500 007

NOTICE INVITING TENDER (NIT)

Tender No.55(2)2015-Pur/T-6
dated 28 April, 2015

**“3D/2D Seismic Job Services and Topographical Survey in the
States of West Bengal and Jharkhand**

Bid Security/E.M.D	:	INR 5.000 lakhs	
BID CLOSING DATE & TIME	:	12-05-2015 -	2.30 pm
TECHNICAL BID (Part – I) OPENING DATE/TIME	:	12-05-2015 -	3.30 pm

TABLE OF CONTENTS

	CONTENTS	PAGE Nos.
1.	INSTRUCTIONS TO BIDDERS	: 3 to 8
2.	TERMS OF REFERENCE/ SCOPE OF WORK	: 9 to 14
3.	SCHEDULE OF RATES	: 15 to16
4.	BID EVALUATION CRITERIA	: 17
5.	GENERAL CONDITIONS OF CONTRACT	: 18 to 23
6.	AGREEMENT FORM	: 24 to 25
7.	BID SECURITY	: 26
8.	INDEMNITY BOND	: 27
9.	PERFORMANCE GUARANTEE	: 28

INSTRUCTIONS TO BIDDERS

- 1.0 National Geophysical Research Institute (NGRI), a research institute under Council of Scientific and Industrial Research (CSIR) presently engaged in R&D work in Earth Sciences in different parts of India, proposes to carry out **3D/2D Seismic and Topographical Survey** in West Bengal and Jharkhand.
- 2.0 Accordingly, National Geophysical Research Institute (NGRI), Hyderabad now invites bids under **Two Part Bidding system** (Techno-Commercial Bid Part-I and Commercial Bid Part - II) from capable and experienced parties for carrying out 3D/2D Seismic survey and Topographical Survey in the above area (in West Bengal and Jharkhand)

3.0 BID DOCUMENTS

- 3.1 The Bidder shall comply fully with the instructions contained in this Bid document. The bidder is expected to examine all instructions, sections, terms and conditions, specifications etc. in the bid documents. Failure to furnish all information, data as required by the bid documents or submission of a bid not substantially responsive to the bid documents in every respect will be at bidder's risk and may result in the rejection of their bid.
- 3.2 Bidders shall bear all costs associated with the preparation and submission of bid etc. NGRI will in no case be responsible or liable for those costs, regardless of the conduct or outcome of the bidding process.
- 3.3 Bids are to be submitted in triple sealed cover. The first inner cover will contain TECHNO-COMMERICAL bids having all details but with price column blanked out. This cover will clearly be super scribed "**TECHNO COMMERCIAL Bid (Part-I)**" bid along with bid number. The second sealed inner cover will contain only the price schedule duly filled in and signed and will be clearly super scribed "**Commercial BID (PART – II)**" along with bid number. These two covers shall be put into an outer cover and sealed. **The outer covers should duly bear the tender number and date of closing/opening of the bid prominently underlined, and should be addressed to the Director, NGRI.**

Bidders desiring to deliver the bid in person may handover the same to the Bid Receiving Officer at NGRI. Bidders may also submit their offers by registered post / speed post to reach NGRI on or before the due date and time.

4.0 EXPERIENCE OF THE BIDDER AND HIS PERSONNEL:

- 4.1 **The bidder as a company should have proven capability/ experience in execution of both seismic Job services and topographical surveys with oil, mineral exploration companies. He should have executed such job of 3D Seismic & Topography for 10 Sq.K.M. and documentary evidences to this effect have to be submitted along with the bid.**
- 4.2 The following documents should be enclosed along with the Bid.
- The original copy of Bid document duly signed on each page as token of having accepted the terms and conditions of the Bid Documents. Proof of experience should be submitted along with techno-commercial (Un priced) bid.
 - Descriptive literature of the bidder's constitution, experience and past performance on similar jobs and capabilities of the personnel.
 - Technical details as per Bid Document duly filled in and signed.
 - Exception, if any, to NGRI's terms and conditions of the contract.

- e) Bidders are required to submit EMD as per Clause 9.1.
- f) Any other information/details as required under Bid Document.

4.3 Bidders shall clearly indicate their legal constitution and person signing the Bid shall state his capacity as also the source of his authority to bind the Bidder. The power of Attorney or Authorization or any other document constituting adequate proof of the powers of the signatory to bind the bidder shall be annexed to the Bid. NGRI will reject outright any Bid unsupported by adequate proof of the signatory's authority.

4.4 The Bidder shall sign his proposal with the exact name of the firm to whom the contract is to be awarded. Executive of the Bidder's organization stating his rank/designation, enclosing a copy of his Power of Attorney to sign the Bid, shall duly sign the Bid.

4.5 **Bidders are required to indicate** the type and quantity of equipment including vehicles and list of personnel & their experience (Seismic Job Services for seismic data acquisition etc.) to be deployed for the services to be rendered by them against this contract.

4.6 Relationship with NGRI.

The bidder shall declare in writing that neither he nor any of his associates is in any way related to any Officer of the rank of Under Secretary or above in CSIR/Laboratories. NGRI may decide not to deal with such firms who fail to comply with the above advice.

4.7 Canvassing in connection with the bid is strictly prohibited and the bid submitted by the successful bidder who resorts to canvassing will be liable for rejection.

4.8 Deleted.

4.10 Site Visit, Local condition etc:

4.10.1 The bidder is advised to visit and examine the site of works and its surroundings and obtain for himself on his own responsibility, all information that may be necessary for preparing the bid and entering in to contract. The visit to the site shall be at the bidder's own risk and expense.

4.10.2 Failure to visit the site or failure to study the bidding documents will in no way relieve the successful bidder from furnishing any material or performing all works in accordance with the bidding documents, as a lump sum contract.

4.10.3 It will be imperative for each bidder to fully inform himself of all local conditions and factors which may have any effect on the execution of the contract as described in the bidding document in their own interest.

4.10.4 It is the responsibility of the bidder that such factors have properly been investigated and considered while submitting the bid proposals and that no claim whatsoever including those for financial adjustments to the contract awarded under the bidding documents will be entertained by NGRI and that neither any change in the time schedule of the contract nor any financial adjustments arising thereof shall be permitted by NGRI.

5.0 INSTRUCTIONS FOR FILLING BIDS

5.1 The Purchaser deem it necessary to amend the Bidding Documents as a result of a clarification, it shall do so. The clarifications and amendments issued would also be hosted on the website of the purchaser for the benefit of the other prospective bidders.

5.2 Bid document shall be filled complete in all respects and shall be submitted together with

requisite information. It shall be complete and free from any ambiguity, changes or interlineations. Bidders should quote for Seismic Job services, vibrator operation, Maintenance etc. as detailed in the scope of work, failing which the offer will be rejected.

- 5.3 The Bidder's Bid and any annotation or accompanying documentation shall be in English Language.
- 5.4 Bidder's shall set their prices/rate in figures preferably type written and without any qualification. Each figure stated should be repeated in words and in the event of discrepancy between the amount stated in figures and words, the rates quoted in words shall be deemed to be the correct amount. Illegible price bids will be rejected outright. Bids containing qualifying expressions subject to minimum acceptance etc. will be disqualified.
- 5.5 No clarifications shall be sought after opening of techno-commercial bids. Conditional bids indicating exceptions/deviations to bid conditions will be summarily rejected.
- 5.6 The bidders who are capable to take up the work shall submit the bids. Bidders should quote a FIRM PRICE and they shall be bound to keep this price firm and without any escalation for any reason whatsoever, until the completion of the contract period.
- 5.7 The price quoted must be NET PER UNIT shown in the schedule of rate and must be clearly shown in figures and words only in Indian currency.
- 5.8 No correspondence after opening of Bid will be entertained from the Bidder. However, if NGRI seeks any clarifications with respect to the bid the same is to be complied with.
- 5.9 Bid from Bidders not complying with the above instructions can be summarily rejected.

6 DATE OF BID SUBMISSION

- 6.1 Bid must be received in the office of Controller of Stores & Purchase, **NGRI, on or before 2.30 P.M - 12-05-2015**. The bids **will be opened at 3.30 P.M. on same day** in the presence of bidders who are desirous to be present.
- 6.2 NGRI shall not be responsible for any cost or expense incurred by any bidder in connection with his bidding against this bid and loss of bids in post/courier, regardless of the conduct or outcome of the bidding process.

7. VALIDITY OF BID

- 7.1 The bid must be kept valid for acceptance for 90 days from the date of closure of bid. Validity of bid can be extended by mutual consent
- 7.2 The Mobilization time allowed is maximum 15 days from the date of award of work. Bidder must give an undertaking-confirming acceptance of this clause.
- 7.3 The successful Bidder shall be required to execute a Contract on a Non Judicial Stamp Paper of appropriate value soon after receiving Letter of Intent i.e., within 10 days of issue or within such extended time as may be permitted by NGRI in this behalf. For this purpose, the Bidder shall depute his authorized representative along with power of attorney in his favour. Main conditions of the proposed contract have been specified hereinafter under the title "General Conditions of Contract" in the bid document.

8. AREAS OF OPERATION AND SCOPE OF WORK

- 8.1 Area of work in the form of a Map and the detailed scope of work are as given separately

elsewhere in the bid document.

- 8.2 Note: Approximate quantum of work is only for indicative purpose and the exact work volume may change depending on the exploration objectives and the results of the experimental work. No minimum quantum of work is guaranteed.

9. EARNEST MONEY DEPOSIT (EMD)

- 9.1 Bidders are required to submit EMD valid for **135 days** from the date of opening of bid for an amount of **Rs.5.000 lakhs** (Rupees Five lakhs only)

EMD can be in the form of a DD drawn in favor of NGRI, payable at Hyderabad. In case, the bidder chooses to submit bank guarantee, it should be strictly as per proforma attached from a Nationalized / Scheduled Bank.

The firms registered with DGS&D, NSIC, Govt. Public Undertakings, Central Autonomous Bodies and with the CSIR Labs./Instts, if any, are exempted from payment of EMD provided such registration includes the item they are offering and not for services provided by other companies.

- 9.2 The successful bidder is required to extend the validity of the EMD for a further period till the formal contract is signed and performance bank guarantee is submitted.

9.3 **Bids not accompanied by Earnest Money Deposit as mentioned above will be summarily rejected.**

- 9.4 The EMD of unsuccessful Bidders will be returned within 15 days from the date of signing of contract.

- 9.5 EMD shall be forfeited in the following events:

- a. If the Bid is withdrawn or modified or varied in a manner not acceptable to NGRI during the Bid Validity period or any extension thereof.
- b. If a successful Bidder fails to sign the contract.
- c. If a successful Bidder fails to furnish Performance Bank Guarantee within 10 days of signing of contract.

10. RIGHT TO REJECT

NGRI reserves the right to reject any or all bids without assigning any reason whatsoever. NGRI also reserves the right to cancel this bid at any stage without assigning any reason whatsoever.

11. AUTHORISATION

Bidders are at liberty to be present or to authorise their representative at the time of opening of Bid on the date specified. A letter of authorisation along with the bid document must be forwarded to Director, NGRI. The person attending the opening of Bid must produce a copy of this letter in the office. Unless he presents this letter, he may not be allowed to attend the opening of Bid.

12. PERFORMANCE BANK GUARANTEE:

The successful bidder will have to furnish to NGRI, a Performance Bank Guarantee for a sum equivalent to **10% of contract value** from a Nationalized/ Scheduled bank as per proforma enclosed, This Bank Guarantee shall be valid up to 120 days beyond the date of completion of the contract. It shall be submitted within 10 days of signing of contract.

13. GENERAL CONDITIONS

- 13.1 In case of an unscheduled holiday on the prescribed closing/opening day of the bid, the next working day will be treated as schedule prescribed day of closing/opening of the bid.
- 13.2 This bid being under two bid systems, only the techno-commercial bids will be opened on the opening date indicated. Price bids of the short listed bidders will be opened at a later date under intimation to technically shortlisted bidders.
- 13.3 The successful bidder shall conform to all laws including labour laws (Labour registration etc.,) of the State/Central Government. The successful bidder shall indemnify NGRI for any breach of laws committed by him. The successful bidder shall take adequate measures to ensure continuous and unhindered output of work.
- 13.4 The successful bidder shall provide and be responsible for payment of wages salaries, bonus, provident fund, social charges, insurance, accommodations, etc. in respect of workers and supervisors as per the laws, regulations and acts in this respect of Govt. of West Bengal, Jharkhand, Madhya Pradesh and the Govt. of India in force from time to time. at prevailing rates, and provide necessary proof to NGRI for the payment made to their workmen, payment of salaries, bonus, social charges, insurance, food accommodation and medical treatment, etc. to his employees as per the applicable laws as are in force from time to time. A proper record of the payment made to the workers by the successful bidder should be maintained. The successful bidder shall pay the wages directly to the workmen without any intermediary.
- 13.5 Any expenditure incurred by NGRI on behalf of the successful bidder who is under an obligation to bear the expenditure as per the relevant law shall be recovered by NGRI from the successful bidder either by deduction from an amount payable to the successful bidder under the contract or as a debt payable by the successful bidder.
- 13.6 The successful bidder will be required to maintain medical aid facilities, primarily for the Provision of first aid, supply of preventive medication for common types of illness, etc. and any requirement for Hospitalization or further medical treatment of his employees.
- 13.7 The successful bidder at his own cost shall be responsible for workmen's compensation, insurance, public liability insurance to cover injury or death resulting from the use of explosives, automobile liability insurance, etc. and any other liability / protections provided for under the applicable laws, in this respect that are in force from time to time. The successful bidder must provide NGRI with proof of such coverage and in particular regarding insurance under Workmen's Compensation Act 1923, ESI act 1956. Successful bidder should be registered under EPF and Miscellaneous Provision Act 1952. Successful bidder should abide by EPF Act 1952, Workmen Compensation Act 1923, ESI Act 1956, Contract Labour Act 1970 and Interstate Migrant Workmen Act.
- 13.8 The successful bidder will be solely responsible for the welfare of his employees. He will have no claim against NGRI for any injury or death of his employees. He will have no claim against NGRI for any injury or death of his employees whatever be the cause. Public liability claims against his employees will be his sole responsibility. He shall provide satisfactory proof to NGRI that EPF and ESI contribution has been remitted to the concerned authorities for his employees for each billing of the month. Successful bidder shall indemnify NGRI from any claim in future.
- 13.9 The NGRI shall be at liberty and is hereby empowered to deduct the amount of any damage, compensation cost, charges and expenses arising or occurring from or in respect of any such claims or damages from any sum or sums due or to become due to the successful bidder.
- 13.10 The Successful bidder will acquire requisite statutory licenses including, labour license before commencing the work and also should ensure that all laws such as work men's compensation, Family Pension Scheme, Payment of Bonus, Contract Labour Act. 1970.

- 13.11 The Successful bidder should ensure that Safety and security regulations strictly adhered to as per Govt. of India norms. Bidder should provide for all the participating crew members, necessary safety kits like shoes, helmets and winter cloths etc. All vehicles, camps and field crews should carry first aid kits.
- 13.12 Area of work falls in Patratu Block Jarkhand and Rangamati-B block, West Bengal (OR) Radhanagar, Jarkhand. However as investigations will be carried out by the side of Reserve Forest area bidder should take all precautions so that no environmental damage is caused due to their activity. It should be noted that Forest Department will not permit cutting of trees.
- 13.13 The **Time for completion of work is 12 months**, from the date of completion of mobilization, excluding monsoon break.
- 13.14 NGRI reserves the right to terminate the contract at any stage of the work without assigning the reason what so ever.

TERMS OF REFERENCE / SCOPE OF WORK

S. No	Area	3D Seismic	2D Seismic	Topographical Survey
1	Area 1a; Rangamati-B block, West Bengal (OR) Area 1b; Radhanagar, Jarkhand	4.5 Sq. Km	----	4.5 Sq. Km
2	Patratu Block Jarkhand	4.5 Sq. Km	20 LKM	4.5 Sq. Km 3D & 20 LKM 2D

QUANTUM OF WORK:

CSIR-NGRI proposes to acquire **3D/2D seismic Reflection data** in two blocks covering about 9.0 sq km of 3D Seismic i.e. about 11,250 shots and 20 LKM of 2D Seismic as shown in the above table. The work component may be variable 9 ± 4 Sq km. Line location and Lat-Longs of the two blocks are shown in the map. The block positions may change slightly before or during the data acquisition due to the obstructions in the field. This will be decided by the CSIR-NGRI Scientists during the reconnaissance studies of the area

SEISMIC JOB SERVICES consists of following:

- Laying of cables, connecting the BBU's / Geode DZ's / ground electronics and XLU's / LTU's, checking & laying the lines, connecting the batteries to the units, planting the string geophone bunches in a pit so as to avoid wind noise, charging of batteries etc employing sufficient technical and non-technical persons. The entire setup has to be picked up every day in the evening. Successful bidder should make adequate security arrangements to guard total seismic equipment with accessories like spread cables and ground electronics both in study area and in the base camp.
- Proper roads / path ways have to be laid by the successful bidder breaking the bunds between plots and leveling the ground along recording and shot lines which includes clearing of bushes for planting the geophones, laying cables, smooth movement of vibrators / recording truck and other vehicles in the fields. The bunds have to be rebuilt after completion of the work by the successful bidder to the satisfaction of land owner. Any compensation to the land owner for this purpose should be met by the bidder. Compensation to third party as a consequence of damage to public property / crops during field operations (if needed) will also be successful bidder's responsibility. Leveling of site at the end of operations for the day should be carried out without fail and it is the bidder's responsibility to complete this job. JCB/Necessary equipment for the above jobs should be provided by the successful bidder at his cost.
- The successful bidder should lay the Geophones and cables to take minimum of 80 to 120 shots per day.
- The successful bidder has to take responsibility of execution of the entire work as like transportation and storage of cables & geophones, ground electronics, charging of batteries accessories etc., as directed by NGRI officials.
- The successful Bidder has to establish a camp office facility with internet and FAX facility, and sufficient storage place for equipment, parking of NGRI vehicles and 24 hrs power supply near

the base camp/work site. The batteries have to be fully charged everyday over night for next day's field work.

- The successful bidder should provide experienced staff (with relevant equipment for battery charging, cable repair etc) in electronics / soldering, repair of cables, battery charging etc for the entire duration of the field work. Successful bidder has to deploy minimum of sufficient numbers of experienced personnel for entire duration of the work so as to ensure that Seismic line is ready latest by 6.00 AM every working day.
- Checking of cables, Batteries, Geophones, charging of batteries etc. should be carried out during evening so as to make the same available for data acquisition next day.
- It is successful bidder's responsibility to help in re-acquiring data in case of any data loss or bad quality due to bad cables, noise in the line / ground electronics failure. In such case, same should be repeated at successful bidder's cost.
- At the time of recording operations, the successful bidder's men should remain still so as not to create any cultural noise. He has to provide vehicles and hospitality arrangements for inspection teams from CMPDI/ other departments, if required.
- The successful bidder has to employ well experienced personnel with valid heavy duty vehicle driving license to transport vibrators T-15000 /HEMI-50 from field base camp to work site & back. They must be well experienced in Diesel Engine and auto-mobile hydraulics repair / maintenance. They should attend any minor repairs, maintenance of the vibrators and field vehicles etc., during transport and field operations.
- Successful bidder has to make camping and other logistic facilities/arrangements for their field staff, transportation to field site and back. He should also ensure that good HSE policies are followed during field survey strictly. Health and safety of his/her staff is the responsibility of successful bidder.
- **Successful bidder should strictly follow all statutory norms of Health Safety and Environment (HSE).**

Topographical Survey consists of the following:

Topographic survey work as stated in the Quantum of work covering 10 sq km of 3D and 20 LKM of 2D seismic has to be carried out in the following sequential order.

- Complete reconnaissance survey is to be carried out in the study area by the survey party along with NGRI representatives to finalize the study area profile / lines, its accessibility, control points fixation for EDM / DGPS observation, etc. and base map prepared.
- The successful bidder shall lay the seismic lines as decided by the NGRI scientists with equal spacing of 10 m between the geophone locations and Line interval of 10/20 m with shot points as specified by NGRI Officials. The total work comprises of marking points very clearly at specified interval of 10 m either by putting a wooden peg / flag with clear marking on land / trees or any other reference point by assigning a proper picket number or by any other suitable means. Staking report with rough sketch route map of entire work is to be supplied to the seismic party well before commencing seismic data acquisition operation.

- The successful bidder shall fix on the ground, concrete pillars as specified at beginning and ending of each line and at every specified interval point / DGPS control point, which-ever is the nearer.

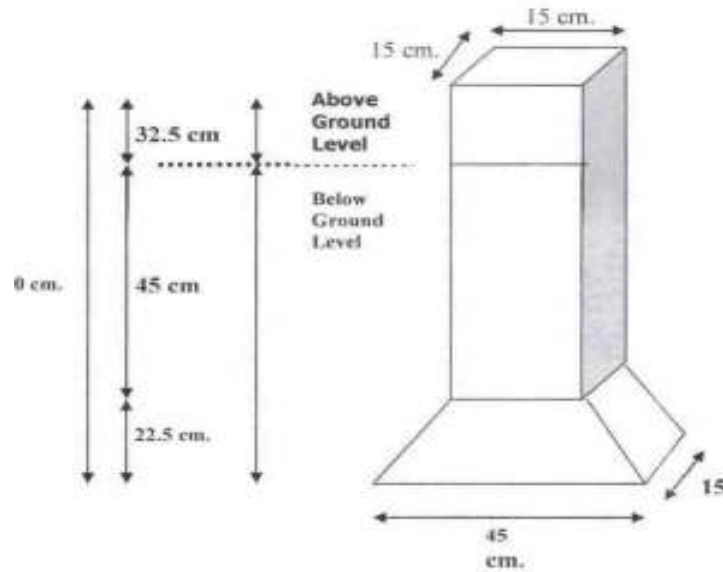

A SKETCH OF THE PILLAR

SURVEY EQUIPMENT:

The survey equipment used for the survey has to be declared in the bid. Successful bidder should show all the equipment with calibration tests to NGRI officials before commencement of the survey. A complete DGPS check shall be carried out before the start of the survey. Manufacturer's recommended tests shall be performed at regular intervals for all the survey instruments / equipment and results submitted to onsite NGRI representatives.

TOPOGRAPHIC SURVEY STANDARDS:

i) Accuracies

The survey error

- Should not exceed 0.1% in 1000m (Horizontal)
- Should not exceed 10cms for surface elevation (Vertical)
- and bearing ± 2 seconds.

ii) Relative Positional Accuracy

- Angular error: 1' between the control points at 500 m to 700 m
- Linear error: 30 cm -40 cm

iii) Levelling

Main loop error shall not exceed $0.025m * K$, where K is the loop distance in kilometers, which is an error of 25 cm/Km.

iv) Spheroid: WGS 84

The successful bidder shall carry out control survey of pillars and picket point implantation using DGPS RTK- GPS technique as generally done for 2D/3D seismic surveys for coal/oil & gas exploration with accuracy better than ± 0.025 m in height and 1:1000 scales. DGPS survey data comprising of WGS84 coordinates, Lambert coordinates should be provided after completion of survey. All the data should be fully compatible to the coordinate system followed by Survey of India.

Successful bidder should also provide records of calibration of survey equipment and performance test to the satisfaction of NGRI representative at any given time. As the area stands to be in restricted forest zone, the topographical maps may be handled with great care with proper security, only to be handled by authorized persons [names of such persons may be intimated to NGRI before commencement of field work]. No photocopy of topo-sheets is allowed at any cost. A complete list of the surveyors along with in-charge of field survey work, who are going to take up the work, may be intimated to NGRI CAMP Party Chief, before commencement of work. In charge of field survey work from successful bidder's side is required to be present for the entire duration of field data acquisition in order to monitor day to day work progress and execution of any change in survey programme / parameter / alignment, as may be required by the NGRI's scientists from time to time.

Two teams are required since the work may be taken up simultaneously or contiguously. .

The total work encompasses 1) marking a point at every 5/10 m. interval clearly either by putting a peg with clear marking of picket number along the given lines 2) providing direction / guidance, to seismic crew, about approach roads 3) giving elevation and location details for each point and 4) erecting pillars providing suitable benchmarks or reference points. Line clearance including payment of compensation like crop damage, bush clearance etc. is to be borne by successful bidder. All the relevant area maps will be provided by NGRI. Total of 10 Sq. Km. area is to be surveyed for the entire job. In addition to this survey work if any topographical survey work required for conducting experimental geophysical work. Any resurvey and re-pegging /marking, if required, will be carried out by the successful bidder at his own cost & responsibility.

The survey party should be available for the entire duration of the seismic survey and till the completion of the work. One survey team should show the survey points on the traverse every day to the NGRI field party and accompany them. In case any semi-permanent markings/pillars (as per enclosed diagram) fixed on the ground are not visible, they should be fixed again.

Deliverables:

- Log of daily work done related to Seismic job services like no. of Geophones, cables, batteries etc used for each shot points, list of shot points covered in each day include repair work if any along with repair works attended.
- Starting and end points, location / picket nos, before starting the day's work and closing.
- Bidder should provide the list of the manpower deployed for the each day's work along with their experience.
- Successful bidder should submit Seismic job services and Topographical survey daily progress reports certified by NGRI party chief in the book form separately.
- All original field data records in ISO 9001:1994 format in bounded volume

- All computation books in bounded volume/register.
- Final rectangular coordinates and height above MSL in meters in volume and in an appropriate media.
- Error listing obtained between different control points and its distribution in coordinates and heights above the MSL be provided along with final data.
- Successful bidder should provide 1: 50,000 scale map and willing to prepare maps of 3 different scales i.e. 1:5000, 1:10000 and 1:50,000. The maps should show all controlled points for traversing and height control may be provided along with the final data. The Successful bidder shall arrange to carry out topographic survey necessary to determine their precise location and elevation of each shot and receiver location and tie the same to the nearest available permanent marks. The successful bidder should also attend any other survey related work.
- Maps (post-pointed) in 1:10,000 & 1:5,000 scale with profile and shot point locations.
- Weekly progress report should be submitted to the Party-Chief, Engineering Geophysics, NGRI camp during the fieldwork at the camp site.
- Returnable materials:
All maps/data books should be returned to NGRI after completion of the work. Successful bidder is responsible for the security of maps/data books while storage and handling. Only the responsible authorized officer should use the data/maps for benefice purposes. No part of the maps/data book should be taken photo-copied without specific permission of Director, NGRI.



AREA-1A; Rangamati Block, West Bengal



AREA-1B; Radhanagar, Jharkhand

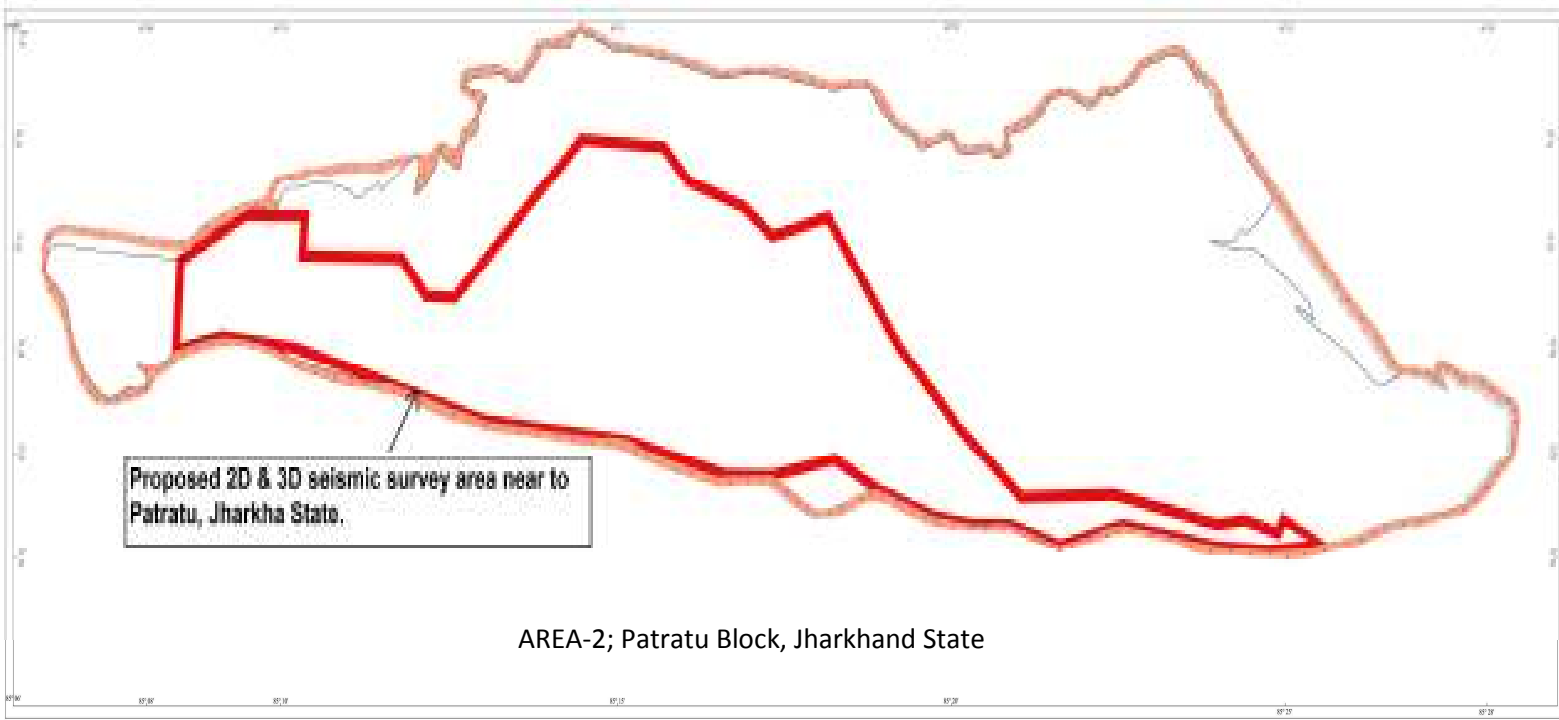

VI. SCHEDULE OF RATES

The bidders are requested to quote the charges exactly as shown in the Proforma

1.0 MOBILIZATION CHARGES

- 1.1 Mobilization charge shall include all costs and charges of mobilization of personnel, all equipment, spares, consumables, accessories etc. This shall include inland transportation, any other charges , taxes, duty, levy etc.
- 1.2 Mobilization charges shall be payable when all personnel, equipment, accessories, etc, are positioned at their appropriate site ready for data acquisition as certified by the company representative.
- 1.3 The bidder shall furnish information of all equipment to be deployed as per the format given.
- 1.4 No mobilization charges shall be paid if the contract is terminated arising out a reason/ act on account of successful bidder

2.0 OPERATING RATE PER SHOT per Channel

The successful bidder shall be paid the operating charges only based on the cost of every shot of acceptable data acquired by the NGRI in requisite format, at actuals. Seismic Job Services charges should include all the charges for the maintenance of equipment / accessories, reports/maps/records generation, mob/demobilization of on/off crews, messing, camp establishment/maintenance and repair/maintenance of support infrastructure, shifting of camp, medical care of personnel, hire of any support infrastructure, Continuous supply of power through generators, communication sets, cables, pegs etc. and day to day operational requirement not specified hereof. The charges are to be mentioned per shot basis. Each shot consists of about 640 to 800 active channels. The number of shots per Sq Km will be decided after experimentation, which may be around 1250 to 2500 shots/ Sq. Km. **For Price computation, 1250 shots / sq.km should be considered and accordingly quote has to be submitted. However, the payment for shots will be made as per actuals.**

4.0 EXPERIMENTAL WORK

The party should carryout experimental work (with all liabilities as applicable to that of production days) before commencing actual data acquisition operations. Three days of experimental work shall be conducted for determining the acquisition parameters. These 3 days shall be distributed before the start of survey and/or any time during the survey which shall be decided by the NGRI's representative with sufficient notice to the successful bidder, to meet the area specific geological/geophysical objectives. **This has to be done at the cost of successful bidder.**

NOTE

- a) Bidders are to note that all charges against which the units rate have been asked, shall be payable only depending upon utilization in actuals.
- b) The quantities indicated are tentative and for Evaluation only
- c) No payment what so ever other than those indicated above shall be paid.

SCHEDULE OF RATES
for Seismic Job Services

RATES TO BE QUOTED BY THE BIDDER

ITEM	UNIT	QTY	UNIT PRICE	TOTAL PRICE
			INR	INR
Mobilisation and Demobilisation cost	Lump sum	One		
Seismic Job Services for acquiring 3D seismic Data	Sq. Km.	1125 shots per sq.km		
Seismic Job Services for acquiring 2D seismic Data	Shot/channel	2000 Shots		
Topographical Survey for 3D	Sq. KM	9.0 Sq.KM		
Topographical Survey for 2D	LKM	20 LKM		
Service tax applicable				
Total (in figures and words)				

* For evaluation purposes only.

However, payment will be as per actual quantum of work done.

Signature of the Bidder
Date:

BID EVALUATION CRITERIA

PARTICULARS	COMPLIED AND ACCEPTED / NOT ACCEPTED
<p>A. TECHNICAL :</p> <p>The following conditions should be complied with in toto, failing which the bid will be rejected.</p> <p>The bidder as a company should have proven capability/ experience in execution of both seismic Job services and topographical surveys with oil, mineral exploration companies. He should have executed such job of 3D Seismic & Topography for 10 Sq.K.M. and documentary evidences to this effect have to be submitted along with the bid.</p>	
<p>B. COMMERCIAL</p> <p>The bids will be evaluated as per total cost which will be arrived based on rates quoted in the schedule of rates.</p>	

GENERAL CONDITIONS OF CONTRACT

1. ADDRESS

1.1 For the purpose of this Contract, the addresses of the contracting parties will be as follows and all correspondences and notices in relation to the present contract sent to the parties to the addresses mentioned below shall be deemed to be sufficient for serving of Notices on the parties concerned.

a) Controller of Stores & Purchase
National Geophysical Research Institute
(Council of Scientific & Industrial Research)
Uppal Road, Hyderabad – 500 606

PH: 040-27012887-27012370/ Fax: 040-2717 1564
e-mail : purchase@ngri.res.in

b) Name and address of the Successful bidder

1.2 The validity of the contract will be for one year.

1.3 NGRI reserves the right to change the period, to instruct the successful bidder in respect of starting and closing of contract operation. NGRI will not be responsible for any compensation whatsoever on this account.

1.4 Mobilisation Period :

Mobilisation means the deployment of requisite crew & equipment, establishment of camp by the successful bidder.

Mobilisation period allowed is maximum 15 days from the date of award of work. Certificate of Mobilisation jointly signed by NGRI authorized representative and successful bidder shall be the proof of Mobilisation.

1.5 **Duration of Survey:** The Seismic Job services and Topographical has to be completed within 12 months (excluding monsoon) spread over in two field seasons.

2. WORK PERFORMANCE STANDARDS

2.1 As detailed in the terms of reference/scope of work.

2.2 NGRI Party Chief is empowered to declare the areas logistically difficult for data acquisition end of the seismic line, last day of the fields work, a limited patch work in a seismic line and experimental work at any time of the operations during the field season in connection with the improvement of data, by reasons of exceptionally inclement weather, by reasons of any proceedings taken or threatened by or of dispute with adjoining owner or public properties, for any other reason which is beyond the control of the successful bidder, and unforeseen circumstances.

3. TERMS AND MODE OF PAYMENT

Mode of payment:

Payment will be made as follows:

a. Mobilization Charges – After completion of mobilization and on certification by authorized NGRI Official.

- b. For the Seismic Job services and Topographical Survey, payment will be made on monthly basis based on actual quantum of work executed..

PAYMENT Procedure .

- a) Successful bidder shall prepare invoices for each day in 2 copies. The successful bidder at the end of each month, should prepare the invoice for the actual work done during the month and enclose the copies of all production invoices duly certified by NGRI Party Chief.
- b) **Party Chief, NGRI** will certify the accepted Shots and amount payable on each invoice form submitted by the Successful bidder and forward the same duly certified, for release of payment.
- c) Successful bidder will raise the bills in the name of Director, NGRI, Hyderabad-500606.
- d) Payment of invoices except the last invoice will be made within 15 days of receipt of invoices. Payment for accepted records and undisputed bills will be made by Director, NGRI, Hyderabad in the form of Account Payee cheque drawn on SBH, Habshiguda Branch/ or will be directly transferred to his account electronically through e-payment mode. Any delay in payment on any account will not make NGRI liable to pay interest, under any circumstances. Disputed bills will be returned to the successful bidder.
- e) The successful bidder shall certify on the body of every bill that he has cleared all dues to the labour employed by him and for all other services hired by the successful bidder during the course of work for the period covered by the bill.
- f) The successful bidder shall certify on the body of every bill that his employees are paid minimum wages not less than those prescribed by law.
- g) The successful bidder shall furnish an indemnity bond to the effect that he shall be responsible for any further claims with regard to the pending payments to be made by him and thus indemnify NGRI against all future claims in this regard pending between the successful bidder and any other party along with the final bill. The final bill will be paid after the formalities specified in this clause are fulfilled.
- h) The successful bidder at his own cost be responsible for workmen's compensation, insurance, public liability insurance to cover injury or death resulting from the use of explosives, automobile liability insurance, any machinery operation etc. and any other liability/protections provided for under the applicable laws, in this respect that are in force from time to time. The successful bidder must provide NGRI with proof of such coverage and in particular regarding insurance under Workmen's Compensation Act, 1923 and ESI Act, 1956. He should be registered under Employees PF and Miscellaneous Provision Act, 1952. The rules of Health, Safety and Environmental (HSE) standards should be followed.
- i) The payment of last bill shall be made after finalization of all bills against the Successful bidder, which shall include any claim, for compensation from NGRI for contravention of any of the clauses in this contract.

Compensation for Public Property

Compensation for damages, if any, such as damages; to crops during Vibrator operations or as a result of conduct of seismic job services and/or movement of his employees and equipment along the line/profile will be successful bidder's responsibility(Also refer clause 3.3) Public Liability Insurance shall be obtained for the duration of the contract.

Pits dug and Ways created by the successful bidder should be filled up and restored to original condition after operation .Otherwise expense incurred by NGRI in doing so will be

adjusted from Successful bidder's bill or can also be adjusted from the amounts payable by NGRI to the Successful bidder.

5. FIRM RATES & CURRENCY OF PAYMENT

The rates payable under this contract herein above shall be firm throughout the period of the contract and no escalation shall be allowed under any circumstances.

- 5.1 All payments to the successful bidder under this contract shall be made only in Indian Rupees.

6. TAXES

The successful bidder shall be responsible to pay all taxes and duties such as corporate tax, service tax, turnover tax, sales tax, excise duty, etc., leviable on them and their employees including sub-successful bidders, if any, under the Indian income tax laws or any other laws enacted by the Central or State Govt. on account of payments received by them under this contract. Successful bidder shall maintain all relevant records pertaining to the taxes and submit the same before tax or other authorities and to NGRI as and when required. **TDS will be deducted by NGRI as per clause No.194 (J) of TDS rules.**

7. LIQUIDATED DAMAGES FOR DELAY IN MOBILISATION & EXECUTION OF WORK

1. Mobilisation period allowed is maximum 15 days from the date of award of contract.
2. In case the successful bidder fails to mobilize and start his work on or before expiry of 15 days, as above, liquidated damages at the rate of half percent of contract price per week or part thereof for such delay will be levied. This L/D however will not exceed 5% of the total contract value. This will apply even though the successful bidder is allowed to mobilize after 15 days due to reasons acceptable to the NGRI.
3. **If the work is not completed within 12 months (excluding monsoon break), from the date of completion of mobilization,** liquidated damages at the rate of 0.5% of contract price per week or part thereof for such delay will be levied, subject to maximum of 10% of contract value.

8. FORCE MAJEURE

Neither party shall be held responsible for non-fulfillment of their respective obligations under this agreement due to the exigency of one or more of the force majeure events such as but not limited to Acts of God, war, flood, earthquakes, strike, lockouts, epidemics, riots, civil commotion etc. provided on the occurrence and cessation of any such events, the party affected thereby shall give a notice in writing to the other party within one month of such occurrence or cessation. If the force-majeure conditions continue beyond six months, the parties shall then mutually decide about the future course of action.

In the event of either party being rendered unable by Force Majeure to perform any obligation required to be performed by them under the contract, the relative obligation of the party affected by such Force Majeure shall upon notification to the other party be suspended for the period during which such cause lasts.

Unrest / strike by the successful bidder's personnel shall not be construed as force majeure.

9. OTHER CONDITIONS

- 9.1 The Successful bidder shall obtain license under the Contract Labour (Regulation and Abolition) Act, 1970 from the Competent Authority. Only upon production of such license, the first payment of the successful bidder shall be released. The Successful bidder shall renew his license during the contract period if required. At the end of the contract work, the successful bidder shall furnish to NGRI an indemnity Bond on non-judicial stamp paper to the effect that all wages/dues of the workmen engaged by him or by his sub-successful bidders have been fully paid for the entire contract period. Without this Certificate, performance Bank Guarantee will not be released.
- 9.2 The successful bidder shall arrange to give all notices required under various laws to all authorities and to pay to such authority or to any public office all fee/penalty that may be payable in respect of the work and lodge the receipt with NGRI on demand. He should be registered under Employees PF and Miscellaneous Provision Act, 1952.
- 9.3 The successful bidder must ensure that his work shall not cause any nuisance to the public in general and to neighboring occupants in particular.
- 9.4 The successful bidder shall not transfer/assign/sublet the contract or any part thereof in any manner without the prior written consent of the NGRI and no such transfer/assignment as and when accepted should relieve the successful bidder of his responsibility under the contract.
- 9.5 The successful bidder shall be responsible for all injuries to the persons, animals or things and for damages to the structural and/or decorative part of property which may arise from the successful bidder's operations, or any of his sub-successful bidder, their employees, due to negligence or otherwise. The successful bidder shall indemnify NGRI and hold it harmless in respect of all and any expense arising from any such injury or damage to persons or property as aforesaid.
- 9.6 Successful bidder shall provide proof to NGRI that EPF and ESI contributions have been remitted to the concerned authorities for his employees for each billing of the month. Successful bidder shall indemnify NGRI from any such claim in future (Public liability claim).
- 9.7 The successful bidder shall conform to all laws including labour laws of the State/Central Government. The successful bidder shall indemnify NGRI for any breach of laws committed by him. The successful bidder shall take adequate measures to ensure continuous and unhindered output of work.
- 9.8 The successful bidder shall provide and be responsible for payment of wages at prevailing rates and provide necessary proof to NGRI for the payment made to their workmen, of salaries, bonus, social charges, insurance, food, accommodation and medical treatment, etc. to his employees as per the applicable laws as are in force from time to time.
- 9.9 The successful bidder shall pay the wages directly to the workmen without any intermediary.
- 9.10 If any amenity required to be provided under the relevant laws for the benefit of the successful bidder's employees is not provided by the successful bidder within the time prescribed thereof such amenity shall be provided by NGRI and all expenses incurred by NGRI in providing the aforesaid amenities shall be recovered by NGRI from the successful bidder either by deduction from any amount payable to the Successful bidder or as a debt payable by the successful bidder.
- 9.11 The successful bidder shall be responsible for enforcing strict discipline amongst his employees and also ensure strict compliance with safety regulations and procedures as required by the Govt. and provide all kits & liveries to their employees. The successful bidder shall indemnify NGRI against any injury / loss of life of any of his personnel at any time

during the tenure of the contract. NGRI shall not be liable for any claim for any accident resulting in loss of life or injury to any workman or supervisor, resident representative etc. of the successful bidder for whatever reason.

10. TERMINATION

- 10.1 In the event of the Successful bidder at any time during the term of this contract becomes insolvent or makes a voluntary assignment of its assets for the benefit of creditors or is adjudged bankrupt, then, NGRI shall by a notice in writing have the right to forthwith terminate this contract.
- 10.2 In all cases of termination the obligation of NGRI to pay charges shall be limited to the period up to the date of termination. Notwithstanding the termination of this contract the parties shall continue to be bound by the provisions of this contract that reasonably requires some action or forbearance after such termination.
- 10.3 If NGRI considers that the performance of the successful bidder is unsatisfactory or not up to the expected standard, NGRI shall notify the successful bidder in writing and specify in detail the causes of dissatisfaction. NGRI shall have the option to forthwith terminate the contract, if successful bidder fails to comply with the requisitions contained in the said written notice issued by NGRI within ten days of the receipt thereof.
- 10.4 In case the successful bidder's right and/or obligations under this contract are transferred or assigned without prior written consent of NGRI. NGRI may at its absolute discretion terminate this contract, without prejudice to the other rights it has under the contract.
- 10.5 If the successful bidder fails to provide requisite job services for data acquisition for any five working days in a month, the contract may be terminated by NGRI unilaterally giving only ten days notice without having any liability on the part of NGRI to pay compensation, damages for the termination of the contract. In addition, NGRI without prejudice to the rights of the owner of the site for damages caused, if any, during course of work, will be at liberty to recover the cost of damages, if any, from the successful bidder.

11. LIABILITY AND INDEMNITY

- 11.1 The Successful bidder agrees to indemnify, defend and hold NGRI harmless from and against any and all claims, suits or causes of action for injury to or worth of successful bidder's personnel and for loss or damage to property of successful bidder or his personnel arising from or related to performance of this contract, and without regard to the negligence or fault of any party.
- 11.2 Except as otherwise specified in Article 11.1 above, NGRI agrees to indemnify defend and hold successful bidder harmless from and against any and all claims, suits or causes of action for injury to or death of loss of damages to the property or persons belonging to its employees arising from or related to performance of this contract and without regard to negligence or fault of any party.

12. NGRI'S RIGHT TO QUESTION STATEMENT AND AUDIT

- 12.1 Payment of any invoice shall not prejudice the right of NGRI to question the allow ability under this contract of any amounts claimed therein, provided NGRI within two years after the date of any such invoice, delivers to successful bidder a written notice identifying any item(s) which it questions and specifying any item(s) which it questions and specifying the reasons therefore. Should NGRI so notify successful bidder, such adjustment shall be made, as the parties shall agree.
- 12.2 Successful bidder shall maintain a complete and correct set of records with details pertaining to his invoices, Payments and claim details thereof. NGRI shall have the right to inspect and

Audit at Successful bidder's office where such records relating to the above are kept within a period of two years from the date of the invoice.

13 CONSEQUENTIAL DAMAGES

Neither NGRI nor the successful bidder shall have any claim against the other for any consequential damages. The term consequential damages herein shall include without limitation to the meaning, loss of profit and business opportunity of use of assets.

14 JURISDICTION AND APPLICABLE LAW

This contract shall be governed by the laws of India and shall be subjected to the jurisdiction of courts in Hyderabad.

15 JURISDICTION AND APPLICABLE LAW

This contract shall be governed by the laws of India and shall be subjected to the jurisdiction of courts in Hyderabad.

16 SEVERABILITY

Should any provision of this contract be found to be invalid, illegal or otherwise not enforceable by any court of law, such finding shall not affect the remaining provision and they shall remain binding on parties hereto.

17. FAIRNESS AND GOOD FAITH

The Parties undertake to act in good faith in respect to each other's rights under this Contract and to adopt all reasonable measures to ensure the realization of the objectives of this Contract.

18. ARBITRATION

Except as hereinbefore provided, all disputes arising out of or in connection with this contract shall be amicably settled or else the same be referred to the sole arbitration of a person nominated by Director General, CSIR as such Arbitrator. The arbitration proceedings shall be held under the Indian Arbitration and Conciliation Act, 1996 and the statutory modification or re-enactment thereof, if any, and the rules made there under for the time being in force shall apply to such arbitration and this deed shall be deemed to be submission to arbitration within the meaning of the said Act. The cost of the arbitration shall be shared between the Parties. The award of the Arbitrator shall be final and binding on the parties.

The venue of the arbitration shall be Hyderabad, India.

19. ASSIGNMENT

The rights and obligations of the Successful bidder shall not be assigned without the prior written consent of NGRI.

20. INTERPRETATION

The titles and headings given in this Contract are inserted for convenient reference only and shall not be construed as limiting or extending the meaning of any provisions of this contract.

AGREEMENT FORM

This agreement made and entered into on _____ day of _____, 2015

Between

CSIR (Council of Scientific & Industrial Research) a Society registered under the Societies Registration Act (XXI of 1860), having its registered office at 'Anusandhan Bhavan' 2, Rafi Marg, New Delhi – 110 001 (hereinafter called CSIR which expression shall where the context so admits include its successors and permitted assigns) of the one part.

AND

_____ (Name of the Party) a _____ (Company) registered in India under the _____ (Act No. & Year) and having its registered office at _____ (Address) (hereinafter called the PARTY which expression shall where the context so admits include its successors and permitted assigns) of the other part.

S.2 Preamble

Whereas CSIR through its National Geophysical Research Institute, Hyderabad, hereinafter referred to as NGRI invited competitive bids vide its bid enquiry No. for Seismic Job Services and Topographical Survey in the States of West Bengal and Jharkhand and the bidding documents thereof.

And whereas the successful bidder submitted its offer vide _____ dated _____ claiming it has sufficient technical and management know-how and has offered to deploy their equipment and personnel as detailed in this agreement for shothole drilling for CSIR/NGRI.

And whereas CSIR/NGRI has issued a firm Letter of Intent No. _____ on _____.

NOW THEREFORE, the parties hereby agree as follows :-

S.3. The following documents attached hereto shall be deemed to form an integral part of this contract.

- i. The General Conditions of Contract
- ii. Terms of Reference / Scope of Work
- iii. Original Bid document
- iv. Price Bid
- v. LOI
- vi. Acceptance Letter
- vii. Any other Information

S.4. The mutual rights and obligations of CSIR/NGRI and the Successful bidder shall be as set forth in the contract, in particular:

- (i) The Successful bidder shall carry out the Services in accordance with the provisions of the Contract; and

(ii) The NGRI shall make payments to the Successful bidder in accordance with the provisions of the Contract.

IN WITNESS THEREOF, EACH PARTY HAS EXECUTED THIS CONTRACT AS OF THE DAY AND YEAR FIRST ABOVE WRITTEN.

SIGNED, SEALED AND DELIVERED

On behalf of the Successful bidder

On behalf of the CSIR/NGRI

()

()

WITNESSESS:

(1) _____

(1) _____

(2) _____

(2) _____

BID SECURITY FORM (EMD)

Whereas _____ (hereinafter called the bidder") has submitted their offer dated _____ for the _____ supply of _____ (hereinafter called the bid") against the purchaser's bid enquiry No. _____ KNOW ALL MEN by these presents that WE _____ of _____ having our registered office at _____ are bound unto _____ (hereinafter called the "Purchaser") In the sum of _____ for which payment will and truly to be made to the said Purchaser, the Bank binds itself, its successors and assigns by these presents. Sealed with the Common Seal of the said Bank this _____ day of _____ 20_____.

THE CONDITIONS OF THIS OBLIGATION ARE:

- (1) If the bidder withdraws or amends, impairs or derogates from the Bid in any respect within the period of validity of this bid.

If the bidder having been notified of the acceptance of his bid by the Purchaser during the period of its validity:-

- (2) If the bidder fails to furnish the Performance Security for the due Performance of the contract.
- (3) Fails or refuses to accept/execute the contract.

WE undertake to pay the Purchaser up to the above amount upon receipt of its first written demand, without the Purchaser having to substantiate its demand, provided that in its demand the Purchaser will note that the amount claimed by it is due to it owing to the occurrence of one or both the two conditions, specifying the occurred condition or conditions.

This guarantee will remain in force upto and including 45 days after the period of bid validity and any demand in respect thereof should reach the Bank not later than the above date.

(Signature of the authorized officer of the Bank)

Name and designation of the officer

Seal, name & address of the Bank and address of the Branch

INDEMNITY BOND

We M/s having Registered Office at hereby indemnify NGRI, Hyderabad, India and acting with regard to Contract No. _____ dated _____ for _____ we fully indemnify NGRI against any future claims with regard to the pending payments to be made by us and thus indemnify NGRI from all future claims if any payments in this regard pending between us and other party.

We indemnify NGRI against any penalties / claims arising from any default on our part in complying with the provisions and obligations under Contract Labour (Regulation and Abolition) Act, 1970 and rules hereunder.

We further indemnify NGRI to the effect that all wages / dues of the workman engaged by our sub-successful bidder or us have been fully; paid for the entire contract period by us. We indemnify NGRI against any default on our part in complying with the status / laws of the local authorities, State and Central Government. We further indemnify NGRI and hold it harmless in respect of all or any expenses arising from any and all injury to the persons, animal or things and for all damages to the structural and or decorative part of property which may arise from the operations or our neglect, whether such injury or damage Arisen from carelessness, accident or any other cause whatever in any way connected with the carrying out of the aforesaid contract. We also indemnify NGRI in respect of injury or damage under Acts compensation or damages consequent upon such claim. We further indemnify NGRI against all claims which may be made against NGRI by any member of the public or their party in respect of anything which may arise in respect of the wok or in consequence thereof and caused by our negligence or negligence of our representative / employees.

We further indemnify the NGRI in respect of any costs, charges or expenses arising out of any claim or proceedings at law and also in respect of any award of compensation or damages arising there from. NGRI shall be at liberty and is hereby empowered, to deduct the amount of damages, compensations, costs charges and expenses as above said from sums may be due to us. We further indemnify NGRI in respect of any claims/issues arising out of the execution of the contract and no claims are pending with NGRI against the contract referred as above.

This indemnity Bond executed this day the _____

PERFORMANCE SECURITY FORM

MODEL BANK GUARANTEE FORMAT FOR PERFORMANCE SECURITY

To

.....

WHEREAS(name and address of the supplier) (hereinafter called "the supplier") has undertaken, in pursuance of contract no. datedto supply (description of goods and services) (herein after called "the contract") AND WHEREAS it has been stipulated by you in the said contract that the supplier shall furnish you with a bank guarantee by a scheduled commercial bank recognized by you for the sum specified therein as security for compliance with its obligations in accordance with the contract;

AND WHEREAS we have agreed to give the supplier such a bank guarantee; NOW THEREFORE we hereby affirm that we are guarantors and responsible to you, on behalf of the supplier, up to a total of (amount of the guarantee in words and figures), and we undertake to pay you, upon your first written demand declaring the supplier to be in default under the contract and without cavil or argument, any sum or sums within the limits of (amount of guarantee) as aforesaid, without your needing to prove or to show grounds or reasons for your demand or the sum specified therein.

We hereby waive the necessity of your demanding the said debt from the supplier before presenting us with the demand. We further agree that no change or addition to or other modification of the terms of the contract to be performed there under or of any of the contract documents which may be made between you and the supplier shall in any way release us from any liability under this guarantee and we hereby waive notice of any such change, addition or modification.

This guarantee shall be valid until the day of, 2015.....

(Signature of the authorized officer of the Bank)

.....

Name and designation of the officer

.....

Seal, name & address of the Bank and address of the Branch